

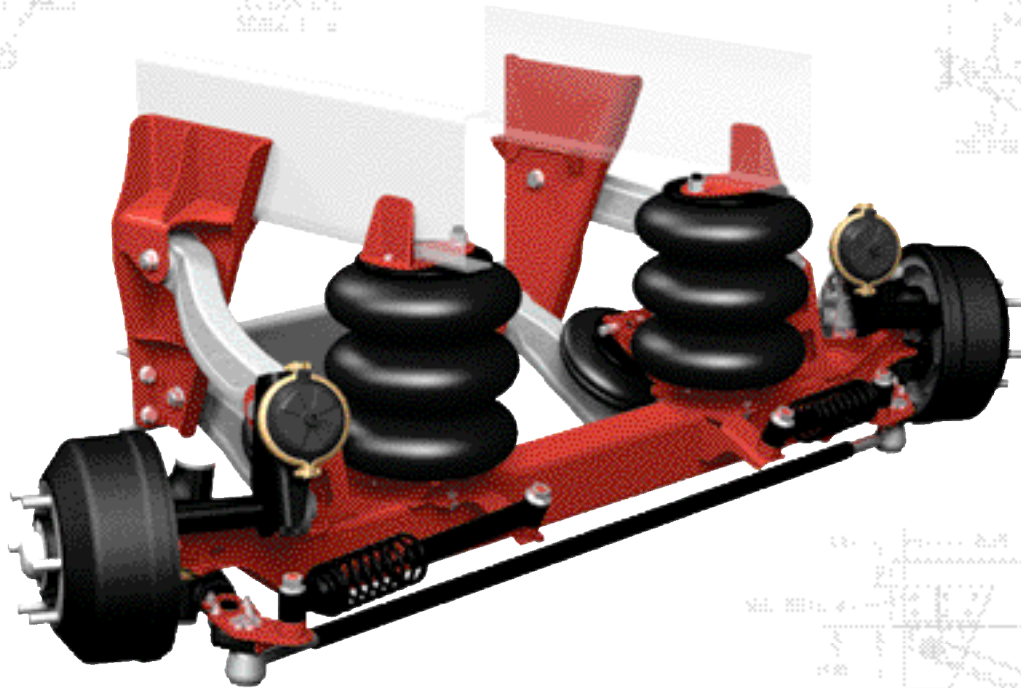

Application of our
Alumilite Technology in an
8K Capacity for Even More
Weight Savings!

Watson Suspension Systems

TRU-TRACK SUPER ALUMILITE SELF-STEERING AXLE & SUSPENSION SYSTEM



SL-0890TT Series

- 5 Year Warranty
- Preloaded Locking Fasteners
- 8,000 lb. Capacity
- Weight: 865 Pounds **including** wheels and tires



LEADERSHIP IN SUSPENSION TECHNOLOGY

SL-0890 Series

TRU-TRACK SUPER ALUMILITE

INTEGRATED SUSPENSION AND AXLE ASSEMBLY

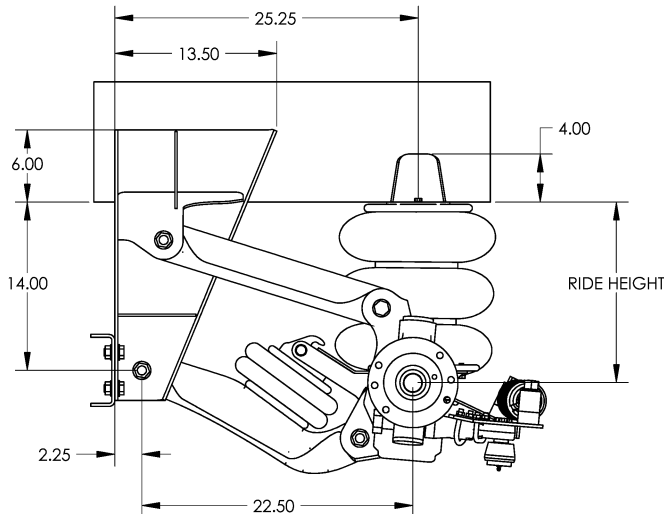

- Axle Travel: 13.5 in.
- Parallelogram Design
- Axle Lift: 10.5 in.
- Preloaded Locking Fasteners
- Capacity: 8,000 lbs.
- Quick Change Ride Height System
- Ride Heights: 12 thru 18 in.
- Preset Caster

The Lightest Lift Axle

Weight Comparison

| Model | Capacity | Weight (Pounds) | | | Alumilite Advantage |
|----------------------------|-------------------|-----------------|--------------------|------------|---------------------|
| | | Suspension (1) | Tires & Wheels (2) | Total | |
| Tru-Track | 13, 200 lbs. | 991 | 278 | 1269 | 404 |
| Tru-Track Lite | 12,000 lbs. | 971 | 278 | 1249 | 384 |
| Tru-Track Alumilite | 8,000 lbs. | 681 | 184 | 865 | |

(1) With standard cast hubs and drums.
 Tru-Track weight with light-weight wheel ends is 944 pounds.
 Tru-Track Light weight with light-weight wheel ends is 924 pounds.
 Light-weight wheel ends not yet available for Tru-Track Alumilite.

(2) Tru-Track and Tru-Track Lite with 255/70R22.5 tires and aluminum wheels.
 Tru-Track Alumilite with 215/75R17.5 tires and aluminum wheels.
 Additional weight savings of 86 pounds when compared with 11R22.5 tires.

Lighter weight is not an advantage unless the suspension is durable enough to stand up in rugged off-road applications. The Tru-Track Alumilite uses the proven Tru-Track parallelogram design and is backed up by our standard **5 year warranty**. You can depend on Watson & Chalin.



Watson Suspension Systems

972.547.6020 800.445.0736

FAX: 972.542.0097

2060 COUCH DRIVE MCKINNEY, TEXAS 75069

www.WatsonSuspensions.com